

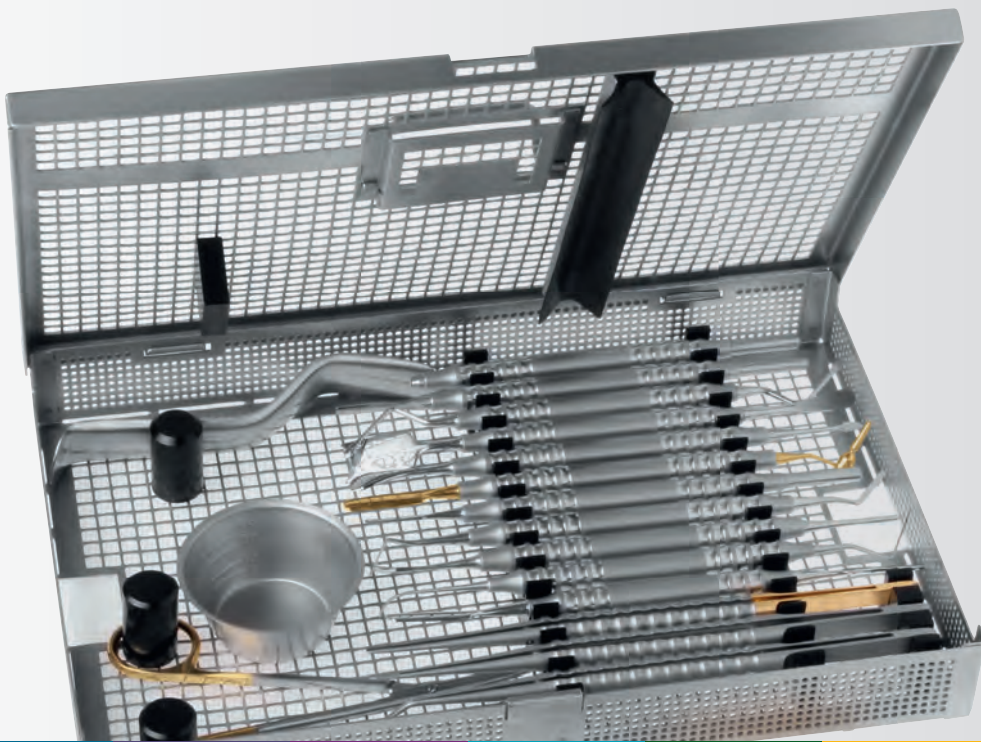

... makes the difference



**RECOMMENDATION OF
DR. HENRIETTE LERNER**

DR. HENRIETTE LERNER

EDUCATIONAL TRAINING

Sept 1985 - June 1990 Doctor Medic. Stom.(D.M.D)
University of Medicine, Temeschburg
Faculty of Dentistry, Romania

January 1990 - July 1993 Oral Surgery Training
Fortbildungsak Academy,
Karlsruhe, Germany

July 1993 Private Dental Practice - Implantology
Periodontology and
Esthetic Dentistry
Bruchsal, Germany

1995 Training Harvard Week

May 1998 DGZI Implantology Specialist

Sept 2002 ICOI Diplomate

Sept 2004 DGOI Implantology Expert

2006-2007 Oral Surgery Training at the
University of Medizin und Farmacology
Carol Davila
Bucharest, Romania

July 2006 Videnti - Private Dental Practice
Baden Baden, Germany
2011 Associate Professor
University Gr. T. Popa Iasi
Romania

2012 Director of DGOI
Baden Baden, Germany

2012 Director of HL Dentclinic, HL
Academy and Seattle Study Club (SSC)
Baden Baden, Germany

MEMBERSHIPS

DGOI (German Society of Oral Implantologie) founding Member,
Expert und Director of the Study Club Baden
Diplomate ICOI (International Congress of Oral Implantologie)
EAO (European Association of Osseointegration)
BDO (Bundesverband Deutscher Oralchirurgen)
ASA (American Society of Aesthetics)
DGÄZ (Deutsche Gesellschaft für Aesthetische Zahnheilkunde)
DGZMK (Deutsche Gesellschaft für Zahn, Mund und Kieferheilkunde)
AACD (American Academy of Cosmetic Dentistry)
Editorial Advisor Prosthetic Implantology Paper Germany



REFEREE ACTIVITY

2000 - now
Main topics:

Advanced Techniques of Augmentation
Soft tissue Management
Aesthetics and Function in Complex Implant Cases
Minimalinvasive Implantologie
Digital planning

by Dr. Henriette Lerner

PPS | Weichgewebs-Extender

PPS | Soft Tissue Extender

PPS | Extenseur pour tissus mous

F-line SL



Durch kurze, ziehende, mit leichtem Druck ausgeübte Bewegungen kann das Periostum gelöst und die Gingiva ausgehnt werden. Diese Technik gewährleistet eine optimale Blutversorgung, vermindert Schwellungen sowie Schmerzen und minimiert Verletzungen der Gefäße.



The periosteum can be loosened and expanded by short, pulling movements exerted with slight pressure. This technique ensures an optimal blood supply, reduces swelling as well as pain and minimizes injuries to the vessels.



Exercer de brefs mouvements de traction en appliquant une légère pression pour décoller et étendre le périoste. Cette technique garantit une irrigation sanguine optimale, diminue les gonflements ainsi que les douleurs tout en minimisant les lésions vasculaires.

PPS 1720 F **F-line**

Lerner 17,1 cm

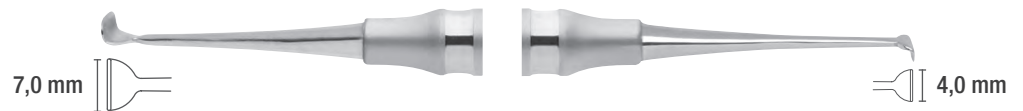

Atraumatische Mikro-Gewebspinzette

Atraumatic micro tissue forceps

Atraumatique micro-pinces à tissus

F-line RS

2302-80 F **F-line**

Lerner 17,1 cm

gerade, glatt
 straight, smooth
 droit, plan



Lochstanze für Membrane

Hole Punch for membrane

Poinçonnage pour membrane

F-line PS

Mit dieser neuen Lochstanze können Membrane problemlos vorgestanzt werden.

With this new hole punch you can pre-punch the membrane without any difficulties.

Le nouveau poinçon permet un pré-poinçonnage aisé des membranes.

4902-90 F **F-line**

Lerner 15,3 cm









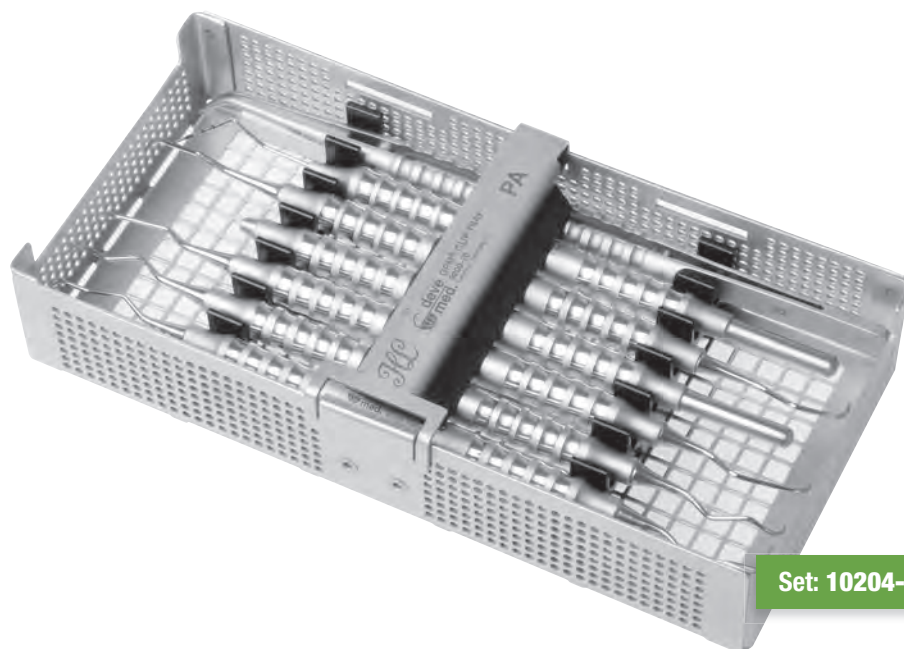

PA/PZR SET nach Dr. Henriette Lerner

PA/PZR SET in accordance to Dr. Henriette Lerner

PA/PZR SET selon Dr. Henriette Lerner



Set: 10204-30

Artikel-Nr. Item no. Articles-Réf.	Bezeichnung Description Description	Set Artikel-Nr.: 10204-30 Item no. of the set: 10204-30 Set complet ref. 10204-30
2385-00 F 	Mundspiegelgriff, M2,5 Mouth mirror handle, M 2,5 Manche de miroir, M 2,5	13,2 cm
2240-20 F 	Pinzette College Tweezers College Précelle Collège	gerieft, 17,3 cm serrated, 17,3 cm striée, 17,3 cm
2525-30 F 	Parodontometer einendig Periodontometers single ended Sondes parodontales simples	graduirt, 3,5-5,5-8,5-11,5 mm graduated, 3,5-5,5-8,5-11,5 mm graduée, 3,5-5,5-8,5-11,5 mm
LAM 01-02 F 	Universal-Kürette Langer Standard # 1-2 Universal Curette Langer Standard # 1-2 Universal Curette Langer Standard # 1-2	17,3 cm
LAM 03-04 F 	Universal-Kürette Langer Standard # 3-4 Universal Curette Langer Standar # 3-4 Universal Curette Langer Standard # 3-4	17,3 cm
LAM 05-06 F 	Universal-Kürette Langer Standard # 5-6 Universal Curette Langer Standar # 5-6 Universal Curette Langer Standard # 5-6	17,3 cm
ZRM M-23 F 	Zahnreiniger Sichel Reiniger „Deppeler“ Scaler sickle scalers „Deppeler“ Déartreurs déartreurs faucilles „Deppeler“	17,3 cm
9200-70 	GPM CLIP Wash Tray (177,5 x 84,5 x 33,0 mm)	

Mundspiegelgriff

Mouth mirror handle
Manche à miroirs

F-line SL

2385-00 F

F-line

M 2,5

13,2 cm



Pinzette

Tweezers
Précelles

F-line RS



2240-20 F

F-line

College

17,3 cm

spitz, mit Querriefung

tipped, with lateral serration

pointu, striure en forme de transversale



Parodontometer | einendig

Periodontometer | single ended
Sondes parodontales | simples

F-line SL

2525-30 F

F-line

CP11.5B (WHO)

16,5 cm

graduieret, 3,5-5,5-8,5-11,5 mm

graduated, 3,5-5,5-8,5-11,5 mm

graduée, 3,5-5,5-8,5-11,5 mm

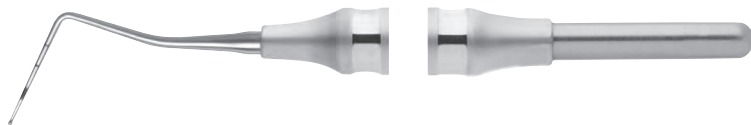

PA/PZR SET nach Dr. Henriette Lerner

PA/PZR SET in accordance to Dr. Henriette Lerner

PA/PZR SET selon Dr. Henriette Lerner

Langer | Universal-Küretten

Langer | Universal Curettes

Langer | Curettes Universelles

F-line SL

LAM 01-02 F **F-line**

Langer Standard # 1-2 17,3 cm



LAM 03-04 F **F-line**

Langer Standard # 3-4 17,3 cm



LAM 05-06 F **F-line**

Langer Standard # 5-6 17,3 cm



Zahnreiniger | Sichel Reiniger

Scaler | Sickle scalers

Détartreurs | Détartreurs faucilles



F-line SL

ZRM M-23 F **F-line**

Deppeler # M-23 17,3 cm





KONS SET nach Dr. Henriette Lerner

KONS SET in accordance to Dr. Henriette Lerner

KONS SET selon Dr. Henriette Lerner



Set: 10400-20



Artikel-Nr. Item no. Articles-Réf.	Bezeichnung Description Description	Set Artikel-Nr.: 10400-20 Item no. of the set: 10400-20 Set complet ref. 10400-20
2385-00 F	 Mundspiegelgriff, M2,5 Mouth mirror handle, M 2,5 Manche de miroir, M 2,5	13,2 cm
2240-20 F	 Pinzette, College Tweezers, College Précelle, Collège	gerieft, 17,3 cm serrated, 17,3 cm striée, 17,3 cm
2525-10 F	 Parodontometer, # EX3A/CP15 Periodontal probe, # EX3A/CP15 Sonde parodontale, # EX3A/CP15	graduier graduated graduation
ZRM 204SD F	 Zahnreiniger 204SD, anterior Scaler 204SD, anterior Déartreur 204SD, antérieur	17,3 cm
1790-20 F	 Füllungsinstrument „Mortonson“ Filling instrument „Mortonson“ Instruments à sculpter „Mortonson“	17,3 cm, 1,4 / 1,8 mm
1701-60 F	 Füllungsinstrument kugelförmig Filling instrument ball-shaped Instrument à sculpter globulaire	17,3 cm, 2,0 / 1,0 mm
1900-11 F	 Füllungsinstrument spatelförmig Filling instrument spatulated Instrument à sculpter spatulé	17,3 cm, 1,5 / 1,5 mm
1655-1 F	 Zementspatel Cement spatulas Spatules à ciment	17,3 cm, 5,0 mm
1999-90 F	 ECI Okklusalformer, kovex konkav ECI Occlusion former, convex concave ECI Modeleur occlusal, convexe concave	17,3 cm, Ø 2,0 mm
PPS 1500 F	 PPS Gewebetransplantat Stopfer PPS Plugger for tissuegraft PPS Compacteur pour tissu	für Tunneltechnik, fein gezahnt for lateral tunnel proce., fine serrated pour technique en tunnel, denture fine
9200-80	 GPM CLIP Tray (177,5 x 127,5 x 33,0 mm)	

Mundspiegelgriff

Mouth mirror handle
Manche à miroirs

F-line SL

2385-00 F

F-line

M 2,5

13,2 cm



Pinzette

Tweezers
Précelles

F-line RS



2240-20 F

F-line

College

17,3 cm

spitz, mit Querriefung
tipped, with lateral serration
pointu, striure en forme de transversale



Parodontometer | doppelendig

Periodontometers | double ended
Sondes parodontales | doubles

F-line SL

2525-10 F

F-line

EX3A/CP15

17 cm

graduiert, 1-2-3-...-14-15 mm
graduated, 1-2-3-...-14-15 mm
graduée, 1-2-3-...-14-15 mm

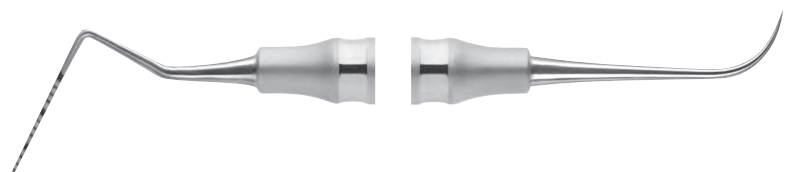

KONS SET nach Dr. Henriette Lerner

KONS SET in accordance to Dr. Henriette Lerner

KONS SET selon Dr. Henriette Lerner

Zahnreiniger | Sichel Reiniger

Scaler | Sickle scalers

Détartreurs | Détartreurs faucilles

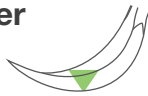

F-line SL

Für schmale Interdentalräume an Prämolaren- und Frontzähnen

For better access to distal surfaces

Pour des espaces interdentaires étroits des prémolaires et des dents antérieures

ZRM 204SD F

F-line

204SD

17,3 cm



Füllungsinstrumente | Stopfer | Planatoren

Filling instruments | Compactors | Planishers

Instruments à sculpter | Compacteurs | Aplanisseur

F-line SL

1790-20 F

F-line

Mortonson

17,3 cm

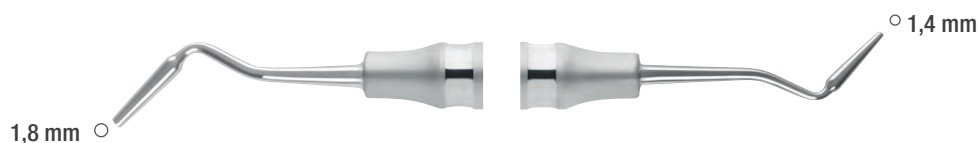

Füllungsinstrumente | kugelförmig

Filling instruments | ball-shaped

Instruments à sculpter | globulaire

F-line SL

1701-60 F

F-line

17,3 cm



Füllungsinstrumente | spatelförmig

Filling instruments | spatulate

Instruments à sculpter | spatule

F-line SL

1900-11 F

F-line

2

17,3 cm



Zementspatel

Cement spatulas
Spatules à ciment

F-line SL

1655-1 F

F-line

17,3 cm

5,0 mm



5,0 mm

ECI | Composite Instrumente für ästhetische Zahnrestorationen

ECI | Composite instruments for aesthetic restorations of teeth
ECI | Instruments composites pour restauration esthétique

F-line SL

(ECI=ESTHETIC COMPOSITE INSTRUMENT)



Instrument für die abschließende Ausgestaltung der okklusalen Konvexitäten.



Instrument for the final design of the occlusal convexities.



Instrument de modelage final des convexités occlusales.

1999-90 F

F-line

17,3 cm

ECI | Okklusalformer, konvex | konkav
ECI | Occlusion former, convex | concave
ECI | Modeleur occlusal, convexe | concave



2,0 mm



2,0 mm

Instrumente für Tunneltechnik

Instruments for tunnel technique
Instruments pour technique en tunnel

F-line SL

In dem bereits präparierten Tunnel wird mit diesem Instrument das Einbringen des Schleimhauttransplantats vorgenommen.

The mucous membrane transplant can be inserted into the pre-prepared tunnel using this instrument.

Sert à introduire le lambeau dans un tunnel préparé.

PPS 1500 F

F-line

PPS

17,3 cm

PPS | Gewebetransplantat Stopfer, fein gezahnt
PPS | Tissue graft plug, fine serrated
PPS | Compacteur pour tissu, denture fine



1,5 mm



1,5 mm



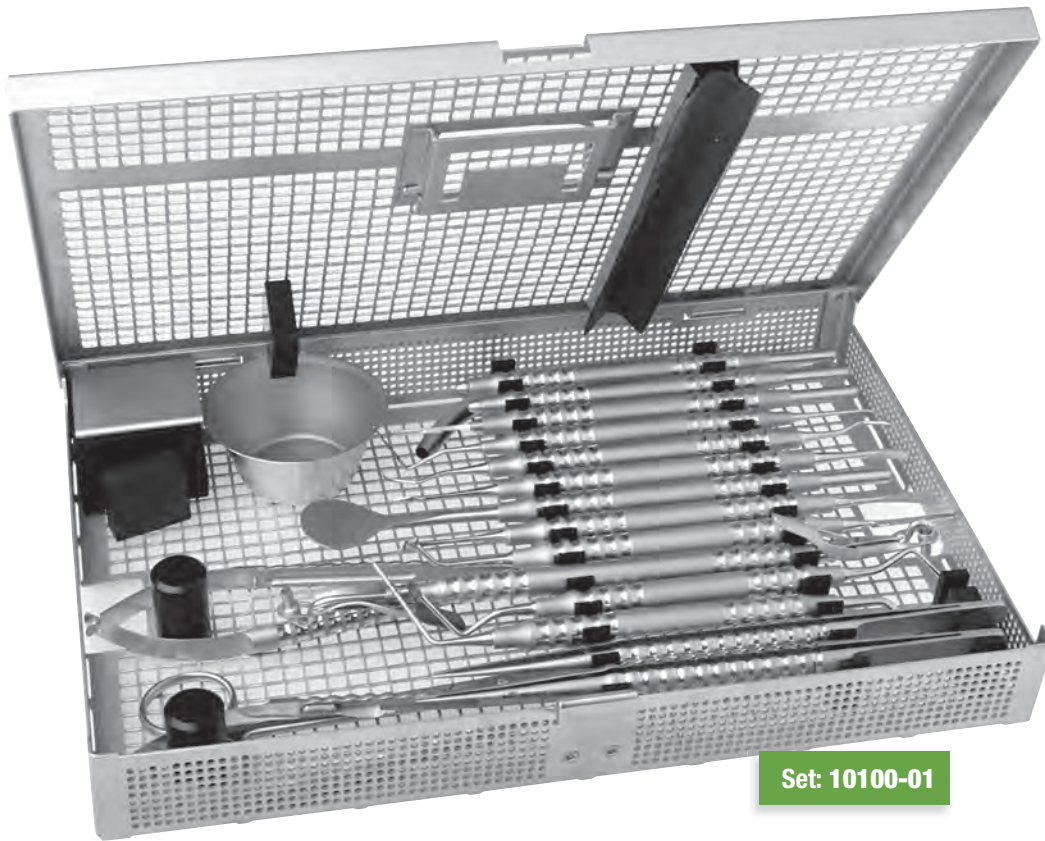

BASIC SURGERY SET nach Dr. Henriette Lerner

BASIC SURGERY SET in accordance to Dr. Henriette Lerner

BASIC SURGERY SET selon Dr. Henriette Lerner



Set: 10100-01

Artikel-Nr. Item no. Articles-Réf.	Bezeichnung Description Description	Set Artikel-Nr.: 10100-01 Item no. of the set: 10100-01 Set complet ref. 10100-01
2385-00 F (2x) 	Mundspiegelgriff, M2,5 Mouth mirror handle, M 2,5 Manche de miroir, M 2,5	13,2 cm
1151-30 F 	Skalpelligriff # 3 Scalpel handle # 3 Manche p. bistouri # 3	gerade, passend für 1 Klinge straight, suitable for 1 blade droit, pour 1 lame
2525-10 F 	Parodontometer # EX3A/CP15 Periodontal probe # EX3A/CP15 Sonde paradontale # EX3A/CP15	graduier graduated graduation
ZRM M-23 F 	Zahnreiniger Sichel Reiniger „Deppeler“ Scaler sickle scalars „Deppeler“ Détartreurs détartréurs faucilles „Deppeler“	# M-23, 17,3 cm

Artikel-Nr. Item no. Articles-Réf.	Bezeichnung Description Description	Set Artikel-Nr.: 10100-01 Item no. of the set: 10100-01 Set complet ref. 10100-01
888-M1 F 	Raspatorium, „Mazor # 1“ Periosteal elevator, „Mazor # 1“ Décolleur, „Mazor # 1“	17,3 cm
888-92 F 	Raspatorium, „Palti“ Periosteal elevator, „Palti“ Rugines, décolleur, „Palti“	19 cm, 22 mm
888-24G F 	Raspatorium „Glickmann“ Periosteal elevator „Glickmann“ Rugines, décolleur „Glickmann“	17,3 cm
2500-40 F 	Stopfer Applikator Compactor Applicator Compacteur Applicateur	17,3 cm
2400-40 F 	Knochenapplikator, „Ivory“ Bone applicator, „Ivory“ Applicateur pour l'augmentation, „Ivory“	20 cm
919-30 F 	Chirurgische Kürette, „Lucas“ Surgical curette, „Lucas“ Chirurgical curette, „Lucas“	3,0 / 3,0 mm, 17,3 cm
2406-91 F 	Tiefenmeßgerät, „Mazor # 7“ Depth gauge, „Mazor # 7“ Jauge de profondeur, „Mazor # 7“	1,5 mm / 3,0 mm; graduert 1,5 mm / 3,0 mm; graduated 1,5 mm / 3,0 mm; graduée
1086-40 F 	Mikro Nadelhalter, Barraquer Micro needle holder, Barraquer Micro porte-aiguilles, Barraquer	17,3 cm, TC, kariert, 0,8 mm, gerade 17,3 cm, TC, chequered, 0,8 mm, straight 17,3 cm, TC, quadrillé, 0,8 mm, droit
2302-60 F 	Atraumatische Mikro-Pinzette Atraumatic tweezers, micro Pince atraum. à dissection, micro	17,3 cm, Cooley, 0,8 mm, gerade, gerieft 17,3 cm, Cooley, 0,8 mm, straight, serrated 17,3 cm, Cooley, 0,8 mm, droits, striée
2302-70 F 	Chirurgische Mikro-Pinzette Dissecting tweezers, micro Pince à dissection à griffe, micro	17,3 cm, TC, 0,8 mm, gerade 17,3 cm, TC, 0,8 mm, straight 17,3 cm, TC, 0,8 mm, droits
1170-65 F 	Chirurgische Mikro-Schere, „Gomel“ Operating micro-scissors, „Gomel“ Micro-ciseaux chirurgicaux, „Gomel“	16 cm, gebogen, fein gezahnt 16 cm, curved, fine serrated 16 cm, courbés, denture fine
1155-6	Chirurgische Schere, 15 cm, „Metzenbaum“ Operating scissors, 15 cm, „Metzenbaum“ Ciseaux chirurgicaux, 15 cm, „Metzenbaum“	TC, gebogen TC, curved TC, courbés
2426-60	Chirurgischer Absauger, Ø 6 mm Suction cannula, Ø 6 mm Tube d'aspiration, Ø 6 mm	mit Bohrung, 14 cm with hole, 14 cm avec alésage, 14 cm
2550-60	Mischdose für Knochenmaterial Mixing bowl for bone material Cuvette de mélange pour mat. osseux	25 cc
10900-10	Set Trepanfräsen mit Bohrerständer Set of trephine burrs with rack Set Trépans avec séquenceur	
9200-10 	GPM Wash Tray (275 x 180 x 35 mm)	mit Deckel mit Haltegriff with cover with handle avec couvercle avec poignée

BASIC SURGERY SET nach Dr. Henriette Lerner

BASIC SURGERY SET in accordance to Dr. Henriette Lerner

BASIC SURGERY SET selon Dr. Henriette Lerner

Mundspiegelgriff

Mouth mirror handle
Manche à miroirs

F-line SL

2385-00 F

F-line

M 2,5

13,2 cm



Skalpellschalenhalter | einendig

Scalpel blade holders | single-ended
Manches de bistouris | simples

F-line SL

1151-30 F

F-line

3

15,8 cm

gerade, passend für 1 Klinge
straight, suitable for 1 blade
droit, pour 1 lame

Der runde Skalpellschalenhalter dient für eine exakt zirkuläre Schnittführung.
Our round scalpel blade holder is perfect for precise circular incisions.
Le manche arrondi permet une incision circulaire précise.



Parodontometer | doppelendig

Periodontometers | double ended
Sondes parodontales | doubles

F-line SL

2525-10 F

F-line

EX3A/CP15

17 cm

graduiert, 1-2-3-...-14-15 mm
graduated, 1-2-3-...-14-15 mm
graduée, 1-2-3-...-14-15 mm



Zahnreiniger | Sichel Reiniger

Scaler | Sickle scalers
Détartreurs | Détartreurs faucilles



F-line SL

ZRM M-23 F

F-line

Deppeler # M-23

17,3 cm

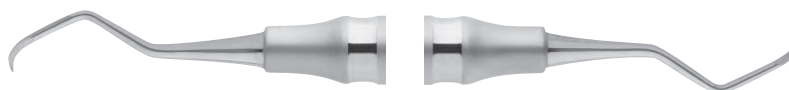

Raspatorien

Periosteal elevators
Rugines, décolleurs

F-line SL

888-M1 F	
Mazor # 1	17,3 cm



Dieses Raspatorium gewährleistet das Lösen des Mukoperiostlappens sowie das Abhalten des Selbigen.



This periosteal elevator allows gentle detachment of the mucoperiosteal flap as well as the flap retraction.



Convient particulièrement au détachement du lambeau muco-périosté de grande taille ainsi que pour la l'écartement du lambeau.

888-92 F	
Palti	19 cm



Das speerförmige Arbeitsteil ermöglicht Ihnen das Ablösen der Papillen sowie das Lösen des marginalen Gingivarandes. Mit der schaufelförmigen Gegenseite wird im Anschluß gewebeschonend der Mukoperiostlappen abgelöst.

The lance-shaped workpiece-end enables the detachment of the papilla as well as detachment of the marginal gingiva crest. The mucoperiosteal flap can then be gently detached with shovel-shaped workpiece-end on the opposite side.

Ce décolleur double à une extrémité en forme de lance qui permet de séparer les papilles ainsi que le bord gingiva marginal. Son extrémité ronde contribue à éloigner le lambeau muco-périosté tout en préservant le tissu.

888-24G F	
Glickmann	17,3 cm



Knochenapplikation

Bone application
Instruments et applicateurs pour l'augmentation

F-line SL

2500-40 F	
	17,3 cm

Stopfer | Applikator
Compactor | Applicator
Compacteur | Applicateur

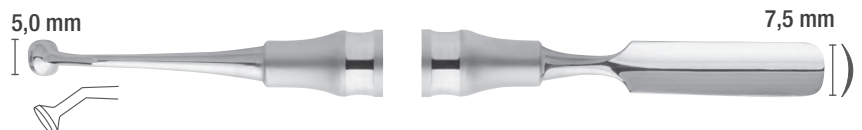

BASIC SURGERY SET nach Dr. Henriette Lerner

BASIC SURGERY SET in accordance to Dr. Henriette Lerner

BASIC SURGERY SET selon Dr. Henriette Lerner

Knochenapplikator

Bone applicator

Applicateur pour l'augmentation

F-line SL

2400-40 F

F-line

Ivory

20 cm



3,5 mm



3,5 mm

Knochenküretten

Bone curettes

Curettes chirurgicales

F-line SL

919-30 F

F-line

Lucas

17,3 cm



3 mm

3 mm

Tiefenmessgeräte

Depth gauges

Jauge de profondeur

F-line SL

2406-91 F

F-line

Mazor # 7

17,3 cm

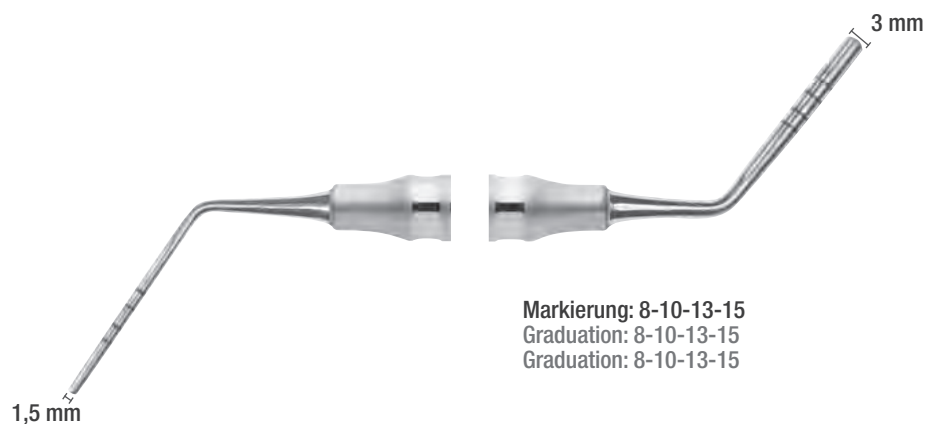

1,5 mm

3 mm

Markierung: 8-10-13-15

Graduation: 8-10-13-15

Graduation: 8-10-13-15

Minimalinvasive Nadelhalter mit Sperre

Minimal invasive needle holders with lock

Porte-aiguilles pour la chirurgie invasive minimisée avec verrouillage

F-line RS

TC

1086-40 F	F-line
Barraquer	17,3 cm 0,8 mm

gerade, mit Kreuzriefung
straight, with cross serration
droit, striure en forme de croix

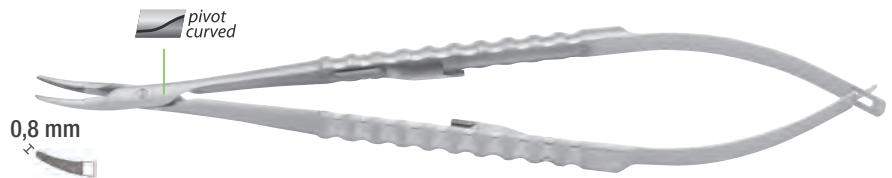

Empfohlen für Fadenstärke:
Recommended for thread size:
Recommandé pour fil à suture:

5-0 – 8-0

Mikro-Pinzetten

Surgical forceps

Pincès chirurgicales

F-line RS

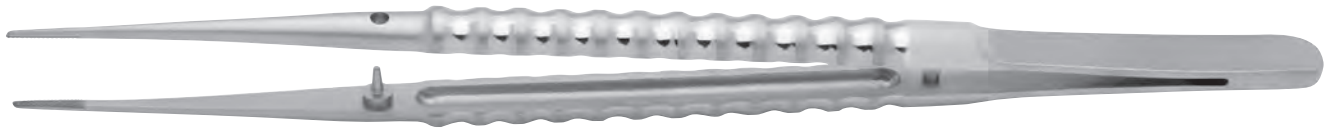

2302-60 F	F-line
Cooley	17,3 mm 0,8 mm

Anatomische Mikro-Pinzette
Anatomical micro forceps
Micro-Pince anatomique

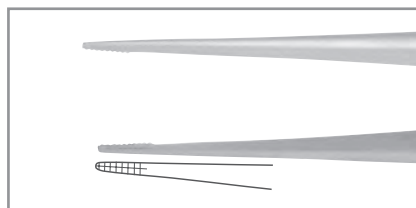

2302-70 F	F-line
	17,3 mm 0,8 mm

Anatomische Mikro-Pinzette
Anatomical micro forceps
Micro-Pince anatomique

TC

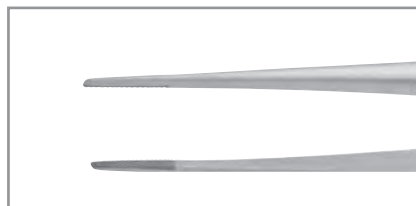

BASIC SURGERY SET nach Dr. Henriette Lerner

BASIC SURGERY SET in accordance to Dr. Henriette Lerner

BASIC SURGERY SET selon Dr. Henriette Lerner

F-line RS

Schere für die minimalinvasive Chirurgie

Scissors for minimalinvasive surgery

Ciseaux pour la chirurgie invasive minimisée



Diese Scheren verfügen über spitze Arbeitssenden mit einem Super-Cut-Schliff. Sie sind gebogen und wurden speziell für die minimalinvasive Chirurgie entwickelt. Wie bei unseren minimalinvasiven Nadelhalter wurde auch hier auf die Möglichkeit einer Drehbewegung geachtet. Somit eignen sich die Instrumente optimal für die Verwendung beim Arbeiten mit der Lupe oder dem Mikroskop.



These scissors have pointed working ends with a Super-Cut finish. They are curved and have been developed especially for minimal invasive surgery. As with the needle holders, the scissors also offer the possibility of a rotary movement. These scissors are ideally suited when working with magnifying glasses or a microscope.



Ces ciseaux ont une partie travaillante très pointue avec un affûtage Super-Cut. Ils sont courbés et ont été spécialement conçus pour la chirurgie invasive minimisée. Comme pour les micro porte-aiguilles, les manches souples conviennent parfaitement au travail sous loupe ou microscope.

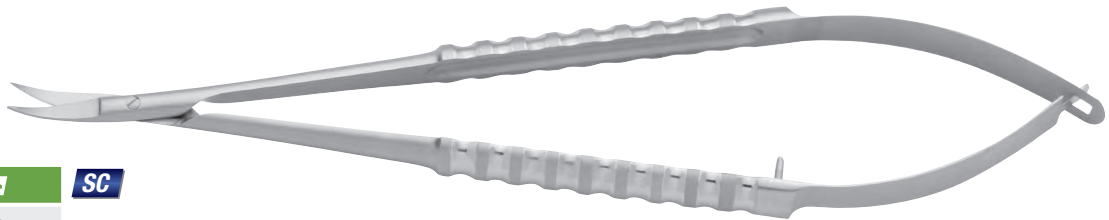

1170-65 F

F-line

SC

Gomel

16 cm

gebogen
curved
courbés

Chirurgische Schere

Surgical scissors

Ciseaux chirurgicaux

1155-6

RC

Metzenbaum

15 cm

gebogen
curved
courbés

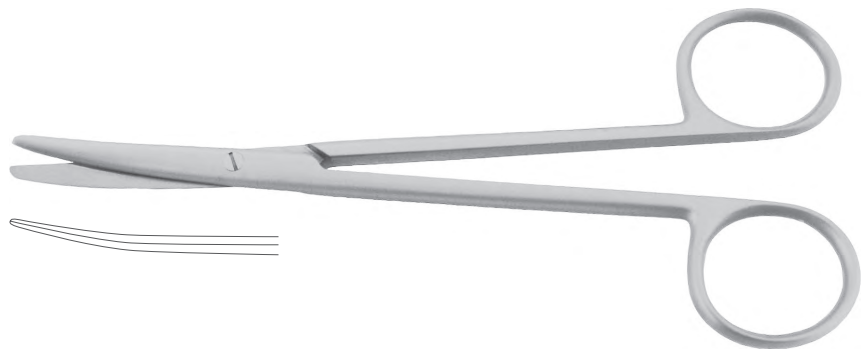

Chirurgische Absaugkanüle

Suction cannula

Canule d'aspirations

2426-60

14 cm
Ø 6 mm

mit Bohrung
with borehole
avec perforation



Mischdosen für Knochenmaterial

Mixing bowls for bone material

Cuvette de mélange pour matériau osseux

2550-60

28 mm
 Ø 60 mm
 25 cc



Trepanfräsen mit Innenkühlung

Trephine burrs with internal cooling

Trépan avec réfrigération

10900-10

Set bestehend aus: 2401-120 bis 2405-601
 Set consisting of: 2401-120 to 2405-601
 Set consiste de: 2401-120 à 2405-601



2401-120

I = 2 mm, A = 3 mm



2401-130

I = 3 mm, A = 4 mm



2401-140

I = 4 mm, A = 5 mm



2401-150

I = 5 mm, A = 6 mm

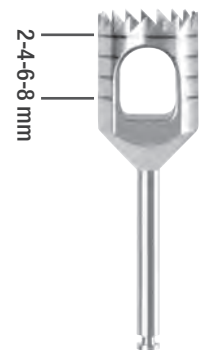

2401-160

I = 6 mm, A = 7 mm



2401-170

I = 7 mm, A = 8 mm



2401-180

I = 8 mm, A = 9 mm



2401-190

I = 9 mm, A = 10 mm

I = Innendurchmesser
 I = Internal diameter
 I = diamètre intérieur

A = Aussendurchmesser
 A = External diameter
 A = diamètre extérieur

Die hier abgebildeten Trepanbohrer sind für alle gängigen Winkelstücke geeignet.

These pictured trephine burrs are appropriate for all angular pieces.

Tous les trépan illustrés conviennent aux embouts courants







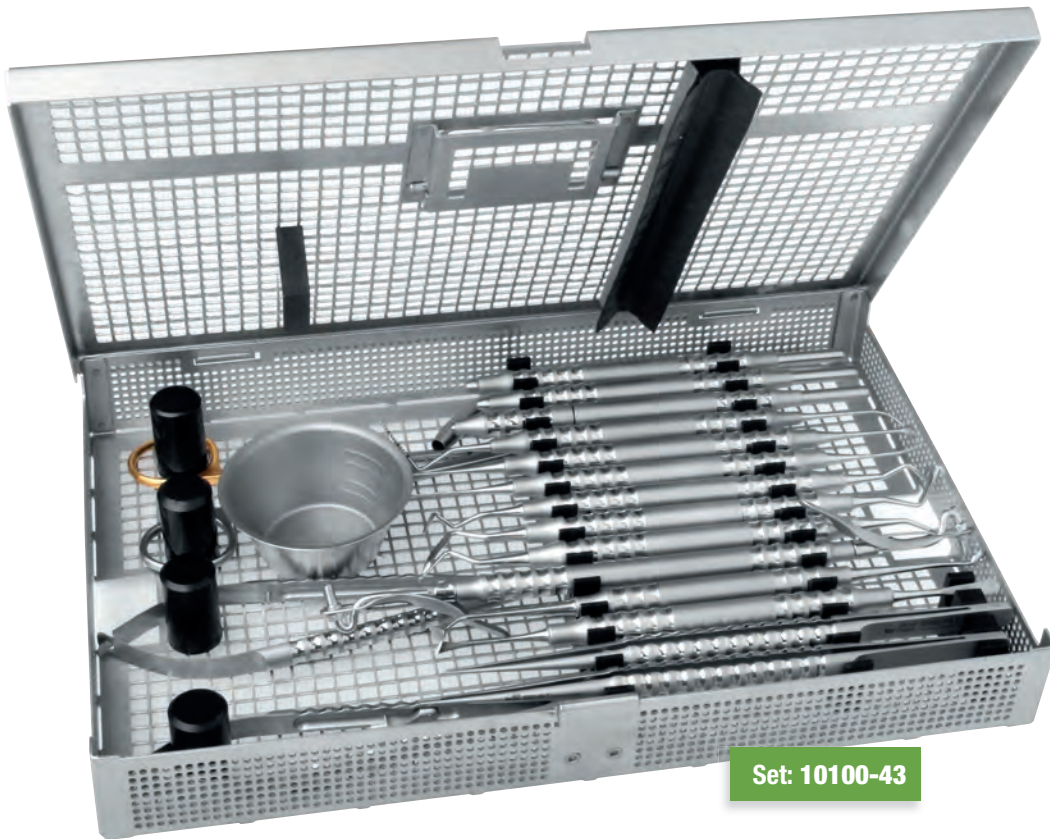







MICRO SURGERY SET nach Dr. Henriette Lerner

MICRO SURGERY SET in accordance to Dr. Henriette Lerner

MICRO SURGERY SET selon Dr. Henriette Lerner



Set: 10100-43

Artikel-Nr. Item no. Articles-Réf.	Bezeichnung Description Description	Set Artikel-Nr.: 10100-43 Item no. of the set: 10100-43 Set complet ref. 10100-43
2385-00 F, 2x 	Mundspiegelgriff, M2,5 Mouth mirror handle, M 2,5 Manche de miroir, M 2,5	13,2 cm
1145-30 F 	Mikroskalpellklingenhalter Holder for micro blades Manche pour micro lames	
2525-10 F 	Parodontometer # EX3A/CP15 Periodontal probe # EX3A/CP15 Sonde paradontale # EX3A/CP15	graduiert graduated graduation
2500-55 F 	Papillenelevatorium Papilla elevator Décolleur papilles	17,3 cm, 2,6 3,6 mm
888-24G F 	Raspatorium "Glickmann" Periosteal elevator "Glickmann" Rugines, décolleur "Glickmann"	17,3 cm
PPS 1000 F 	PPS Raspatorium 2 mm # 1 PPS Periosteal elevator 2 mm # 1 PPS Rugines-décolleur 2 mm # 1	für Tunneltechnik for lateral tunnel procedures pour technique en tunnel
PPS 1200 F 	PPS Gingivektomiemesser # 1 PPS Gingivectomy knife # 1 PPS Couteaux à gingivectomie # 1	für Tunneltechnik for lateral tunnel procedures pour technique en tunnel
PPS 1300 F 	PPS Mukosalappen Präparator PPS Mucosal flap preparator PPS Préparateur p. lamb. muqueux	für Tunneltechnik for lateral tunnel procedures pour technique en tunnel
PPS 1500 F 	PPS Gewebetransplantat Stopfer PPS Plugger for tissuegraft PPS Compacteur pour tissu	für Tunneltechnik, fein gezahnt for lateral tunnel proce., fine serrated pour technique en tunnel, denture fine
2400-40 F 	Knochenapplikator, „Ivory“ Bone applicator, „Ivory“ Applicateur pour l'augmentation, „Ivory“	20 cm
2500-32 F 	Stopfer Applikator Compactor Applicator Compacteur Applicateur	17,3 cm
2302-76 F 	Chirurgische Mikro-Pinzette Dissecting tweezers, micro Pince à dissection à griffe, micro	TC, 0,6 mm, 17,3 cm gerade TC, 0,6 mm, 17,3 cm, straight TC, 0,6 mm, 17,3 cm, droit
2302-60 F 	Atraumatische Mikro-Pinzette Atraumatic tweezers, micro Pince atraum. à dissection, micro	17,3 cm, Cooley 0,8 mm, gerade, gerieft 17,3 cm, Cooley 0,8 mm, straight, serrated 17,3 cm, Cooley 0,8 mm, droits, striée
2426-60	Chirurgischer Absauger Ø 6 mm Suction cannula Ø 6 mm Tube d'aspiration Ø 6 mm	mit Bohrung, 14 cm with hole, 14 cm avec alésage, 14 cm
1153-20	Chirurgische Schere „Kelly“ Operating scissors „Kelly“ Ciseaux chirurgicaux „Kelly“	gebogen, 16 cm curved, 16 cm courbés, 16 cm
2550-60	Mischdose für Knochenmaterial Mixing bowl for bone material Cuvette de mélange pour mat. osseux	25 cc
1086-30 F 	Minimal-invasive Nadelhalter, Barraquer Minimal invasive needle holders, Barraquer Porte-aiguilles pour la chirurgie invasive minimisée, Barraquer	TC, Ø 0,8 mm, 17,3 cm, gerade TC, Ø 0,8 mm, 17,3 cm, straight TC, Ø 0,8 mm, 17,3 cm, droits
1170-65 F 	Chirurgische Mikro-Schere „Gomel“ Operating micro-scissors Micro-ciseaux chirurgicaux	16 cm, gebogen, fein gezahnt 16 cm, curved, fine serrated 16 cm, courbés, denture fine
9200-10 	GPM Wash Tray (275 x 180 x 35 mm)	mit Deckel mit Haltegriff with cover with handle avec couvercle avec poignée

MICRO SURGERY SET nach Dr. Henriette Lerner

MICRO SURGERY SET in accordance to Dr. Henriette Lerner

MICRO SURGERY SET selon Dr. Henriette Lerner

Mundspiegelgriff

Mouth mirror handle

Manche à miroirs

F-line SL

2385-00 F

F-line

M 2,5

13,2 cm



Mikro-Skalpellklingenhalter

Micro-blade holders

Manches pour micro lames

F-line SL

1145-30 F

F-line

14,9 cm

Leicht, drehbar und handlich für eine exakte Schnittführung

Light, rotatable and handy for precise circular incisions.

Facilement maniable pour une incision précise.



Griff durch drehen öffnen und Klinge einschieben

Open handle by turning and insert the blade

Tourner la manche pour ouvrir et insérer la lame

Griff schließen > gebrauchsfertig

Close handle > ready for use

Fermer la manche > Prêt à l'emploi

Parodontometer | doppelendig

Periodontometers | double ended

Sondes parodontales | doubles

F-line SL

2525-10 F

F-line

EX3A/CP15

17 cm

graduiert, 1-2-3-...-14-15 mm

graduated, 1-2-3-...-14-15 mm

graduée, 1-2-3-...-14-15 mm



Raspatorien

Periosteal elevators
Rugines, décolleurs

F-line SL

2500-55 F **F-line**

Wachtel 17,3 cm

Papillenelevatorium, gebogen
Papilla elevator, curved
Décolleur papilles, courbé

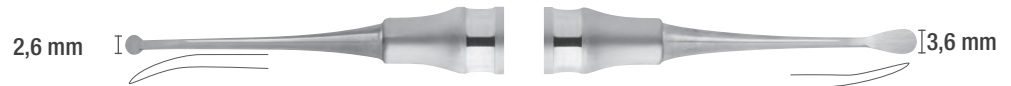

Raspatorien

Periosteal elevators
Rugines, décolleurs

F-line SL



Das speerförmige Arbeitsteil ermöglicht Ihnen das Ablösen der Papillen sowie das Lösen des marginalen Gingivarandes. Mit der schaufelförmigen Gegenseite wird im Anschluß gewebeschonend der Mukoperiostappen abgelöst.



The lance-shaped workpiece-end enables the detachment of the papilla as well as detachment of the marginal gingiva crest. The mucoperiosteal flap can then be gently detached with shovel-shaped workpiece-end on the opposite side.



Ce décolleur double à une extrémité en forme de lance qui permet de séparer les papilles ainsi que le bord gingiva marginal. Son extrémité ronde contribue à éloigner le lambeau muco-périosté tout en préservant le tissu.

888-24G F **F-line**

Glickmann 17,3 cm



Instrumente für Tunneltechnik

Instruments for tunnel technique
Instruments pour technique en tunnel

F-line SL

Angefangen vom Zahnfleischrand wird die befestigte Schleimhaut suprapariosteal mit dem leicht gebogenen Arbeitsteil chirurgisch entfernt. Das leicht gerundete Ende des Arbeitsteils soll ein Durchstechen des Mukosalappens verhindern. Die chirurgische Entfernung wird im Bereich der mobilen Mukosa mit dem geraden, spitzigen Arbeitsteil, minimalinvasiv weiter geführt.

Starting at the Gingival mucosa, the attached mucous membrane can be surgically removed supra-periosteal with the slightly curved workpiece ends. The lightly rounded working part prevent perforation of the mucosal flap. In the mobile mucosa area, the minimally invasive surgical removal can continue with the straight, pointed workpiece ends.

L'extrémité légèrement recourbée de cet instrument permet une dissection sus-périostée de la gencive à partir du bord gingival. La partie arrondie empêche une perforation du lambeau muqueux. Ensuite une dissection peu invasive au niveau de la muqueuse mobile se fait grâce à l'extrémité droite est pointue.

PPS 1000 F **F-line**

PPS # 1 17,3 cm

PPS | Raspatorium
PPS | Periosteal elevator
PPS | Rugines-décolleur



MICRO SURGERY SET nach Dr. Henriette Lerner

MICRO SURGERY SET in accordance to Dr. Henriette Lerner

MICRO SURGERY SET selon Dr. Henriette Lerner

Instrumente für Tunneltechnik

Instruments for tunnel technique

Instruments pour technique en tunnel

F-line SL



Eine spezielle Winkelung und eine Pfeilspitzform an den Arbeitsenden, ermöglichen die Tunnelpräparation der schwer zugänglichen Approximalregionen. Die Papillen werden mittels sehr flach gehaltenen Arbeitsteilen schonend tunneliert.



The workpiece ends are arrow-head shaped and angulated specifically to allow for lateral tunnel procedures in difficult to access approximal regions. The papillae are gently tunnelled by using the very flat workpieces.



Son angle particulier et la forme flèche pointue de l'extrémité permettent une préparation tunnel des régions approximatives difficilement accessibles. Une tunnellation en douceur des papilles est possible grâce à l'extrémité très plate.

PPS 1200 F

F-line

PPS # 1

17,3 cm

PPS | Gingivektomiemesser

PPS | Gingivectomy knife

PPS | Couteaux à gingivectomie



Der Mukosalappen Präparator eignet sich speziell im Bereich der Seitenzähne. Durch die Abwinkelung der leicht gebogenen Arbeitsteile, wird der Zugang und die atraumatische Mukosalappenpräparation ermöglicht.

The mucosal flap preparer is particularly suitable in the posterior tooth area. Access and atraumatic mucosal flap preparation is possible by the lightly curved workpieces.

Conçu pour une utilisation dans la zone dentaire latérale. L'angle légèrement recourbé aux deux extrémités facilite l'accès et la préparation sécurisée du lambeau muqueux.

PPS 1300 F

F-line

PPS

17,3 cm

PPS | Mukosalappen Präparator

PPS | Mucosal flap preparer

PPS | Préparateur pour lambeau muqueux



In dem bereits präparierten Tunnel wird mit diesem Instrument das Einbringen des Schleimhauttransplantats vorgenommen.

The mucous membrane transplant can be inserted into the pre-prepared tunnel using this instrument.

Sert à introduire le lambeau dans un tunnel préparé.

PPS 1500 F

F-line

PPS

17,3 cm

PPS | Gewebetransplantat Stopfer, fein gezahnt

PPS | Tissue graft plug, fine serrated

PPS | Compacteur pour tissu, denture fine

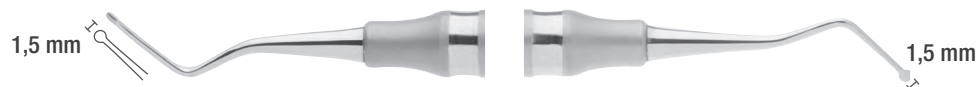

Knochenapplikator

Bone applicator
Applicateur pour l'augmentation

F-line SL

2400-40 F **F-line**

Ivory 20 cm



3,5 mm



3,5 mm

Stopfer | Applikator

Compactor | Applicator
Compacteur | Applicateur

F-line SL

2500-32 F **F-line**

17,3 cm

5,0 mm



5,5 mm

Mikro-Pinzetten

Surgical forceps
Pinces chirurgicales

F-line RS



2302-76 F **F-line**

TC

0,6 mm
17,3 cm

Anatomische Mikro-Pinzette
Anatomical micro forceps
Micro-Pince anatomique

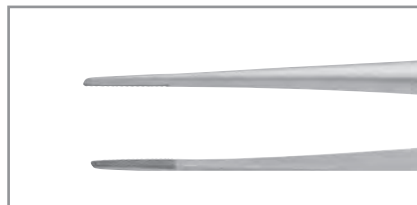

2302-60 F **F-line**

M

Cooley 17,3 mm
0,8 mm

Anatomische Mikro-Pinzette
Anatomical micro forceps
Micro-Pince anatomique

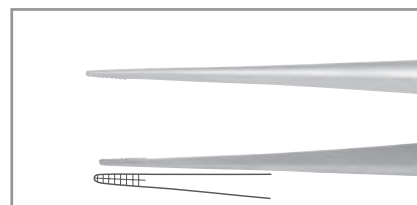

MICRO SURGERY SET nach Dr. Henriette Lerner

MICRO SURGERY SET in accordance to Dr. Henriette Lerner

MICRO SURGERY SET selon Dr. Henriette Lerner

Chirurgische Absaugkanüle

Suction cannula

Canule d'aspirations

2426-60

14 cm
Ø 6 mm

mit Bohrung
with borehole
avec perforation



Chirurgische Schere

Surgical scissors

Ciseaux chirurgicaux

1153-20

SC

Kelly 16 cm

gebogen
curved
courbés

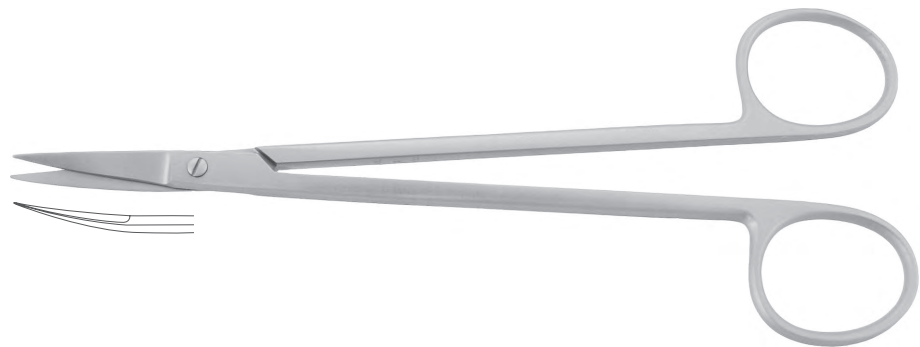

Mischdosen für Knochenmaterial

Mixing bowls for bone material

Cuvette de mélange pour matériau osseux

2550-60

28 mm
Ø 60 mm
25 cc



Minimalinvasive Nadelhalter mit Sperre

Minimal invasive needle holders with lock

Porte-aiguilles pour la chirurgie invasive minimisée avec verrouillage

F-line RS
1086-30 F
F-line
TC

Barraquer

 15 cm
 0,8 mm

gerade, mit Kreuzriefung
 straight, with cross serration
 droit, striure en forme de croix

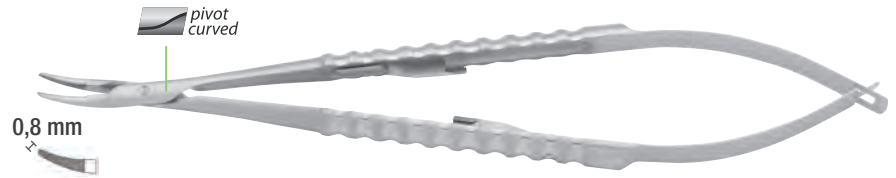

Empfohlen für Fadenstärke:

Recommended for thread size:

5-0 – 8-0

Recommandé pour fil à suture:

Schere für die minimalinvasive Chirurgie

Scissors for minimalinvasive surgery

Ciseaux pour la chirurgie invasive minimisée

F-line RS



Diese Scheren verfügen über spitze Arbeitenden mit einem Super-Cut-Schliff. Sie sind gebogen und wurden speziell für die minimalinvasive Chirurgie entwickelt. Wie bei unseren minimalinvasiven Nadelhaltern wurde auch hier auf die Möglichkeit einer Drehbewegung geachtet. Somit eignen sich die Instrumente optimal für die Verwendung beim Arbeiten mit der Lupe oder dem Mikroskop.



These scissors have pointed working ends with a Super-Cut finish. They are curved and have been developed especially for minimal invasive surgery. As with the needle holders, the scissors also offer the possibility of a rotary movement. These scissors are ideally suited when working with magnifying glasses or a microscope.

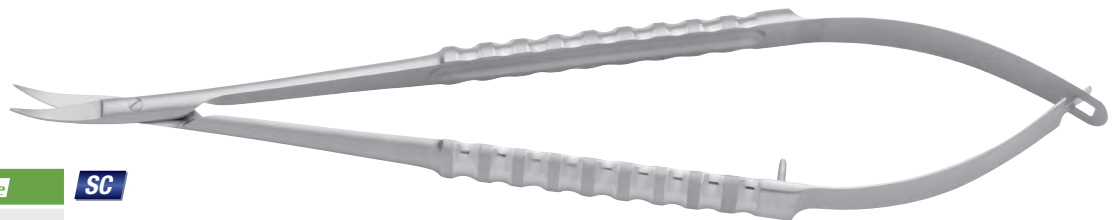

Ces ciseaux ont une partie travaillante très pointue avec un affûtage Super-Cut. Ils sont courbés et ont été spécialement conçus pour la chirurgie invasive minimisée. Comme pour les micro porte-aiguilles, les manches souples conviennent parfaitement au travail sous loupe ou microscope.

1170-65 F
F-line
SC

Gomel

16 cm

gebogen
 curved
 courbés



... makes the difference

devemed GmbH
take-off GewerbePark 30
78579 Neuhausen ob Eck
GERMANY

Tel: +49 (0) 74 67 - 94 91 99-0
Fax: +49 (0) 74 67 - 94 91 99-19

info@devemed.de
www.devemed.de

