

# GPM EDELSTAHL TRAY SYSTEM

GPM-STAINLESS STEEL TRAY-SYSTEM

GPM-SYSTÈME DE CASSETTES EN ACIER INOXYDABLE

# VARIABLE

deveved Instrumente sind mit einer Länge von 171 mm perfekt auf das Tray-System abgestimmt. Im größten GPM Tray können Instrumentenstege horizontal und vertikal eingelegt werden – für beste Raumnutzung.

deveved Instruments with a length of 171 mm are perfectly tailored to the tray system. The instrument racks can be placed horizontally and vertically in the largest GPM tray – for maximum use of space.

Affichant une longueur de 171 mm, les deveved instruments sont parfaitement adaptés au système. Les supports d'instruments peuvent être déposés à l'horizontale et à la verticale dans la plus grande cassette GPM, ce qui permet une utilisation optimale de l'espace.

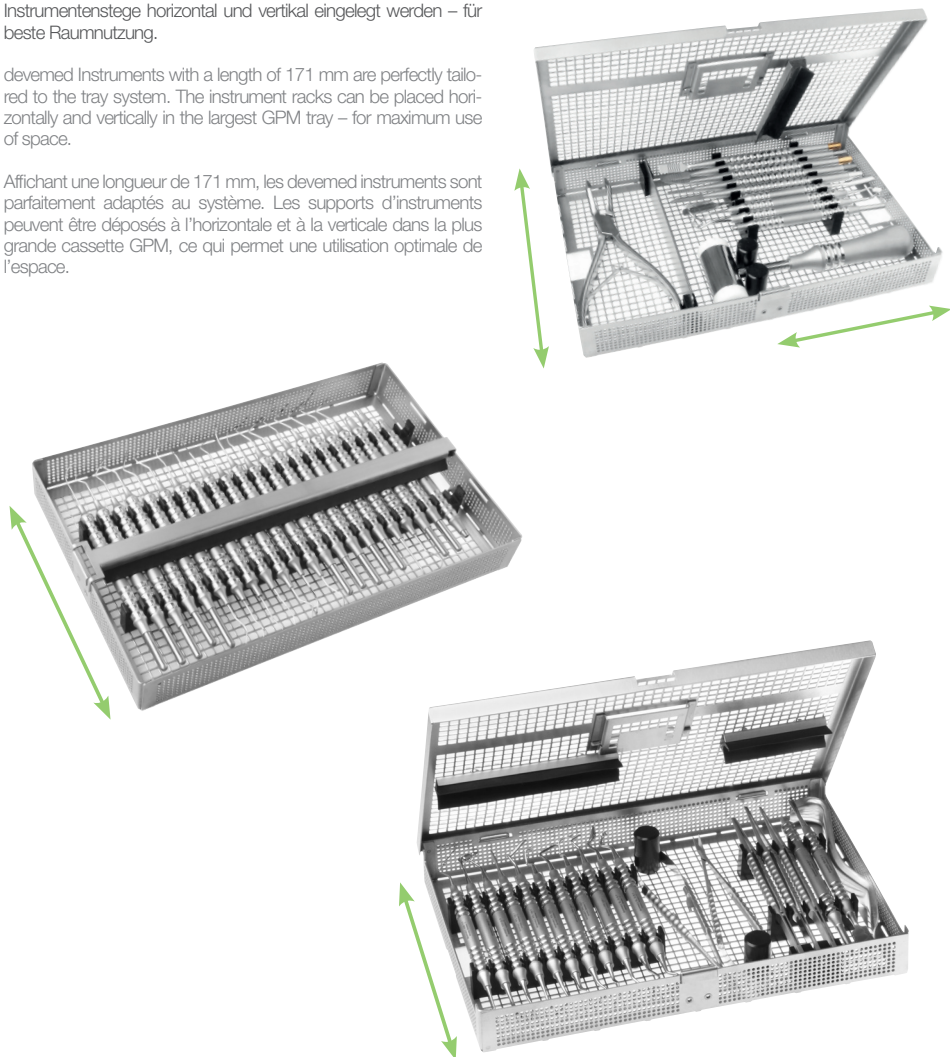

## EFFECTIVE CLEANING

Eine große Perforierung gewährleistet die wirkungsvolle Reinigung.

Effective cleaning is guaranteed due to the large perforations.

Grâce aux grandes perforations, ces cassettes garantissent un nettoyage optimal de vos instruments.

GPM Trays werden aus rostfreiem Edelstahl hergestellt.

GPM Trays are made of stainless steel.

Les cassettes GPM sont en acier inoxydable.

Die Silikonleiste fixiert Instrumente optimal während der Reinigung.

The silicone band is excellent for placing the instruments.

Une fixation en silicone dans le couvercle évite un déplacement des instruments.

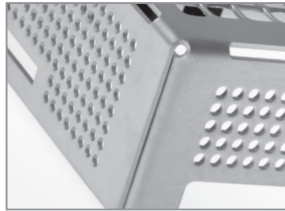
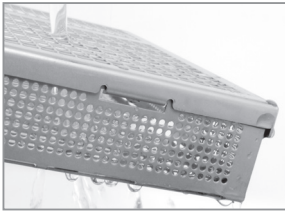

# EASY LOCK

- ✓ Mit dem Druckverschluss *easy lock* können die Trays unkompliziert und einfach geöffnet und geschlossen werden.
- ✓ The pressure-cap *easy lock* enables opening and closing very easy.
- ✓ Le système de fermeture par pression *easy lock* garantit une ouverture et une fermeture confortables et faciles de la cassette.

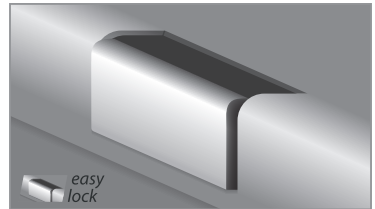

- ✓ Einfaches Öffnen: Den Druckverschluss nach innen drücken und den Deckel nach oben ziehen.
- ✓ Easy opening: Only push the button inwards and pull up the top cover.
- ✓ Ouverture simple: Pressez le bouton à l'intérieur et soulevez le couvercle vers le haut.



- ✓ Schnelles Schließen: Einfach den Deckel nach unten drücken.
- ✓ Quick closing: Push down the top cover.
- ✓ Fermeture rapide: Pressez le couvercle vers le bas facilement.



- ✓ Griff im Deckel ermöglicht einfachen und sicheren Transport
- ✓ Handle in the cover facilitates safe and easy transport
- ✓ Une poignée intégrée dans le couvercle de la cassette GPM permet un transport sûr et facile.

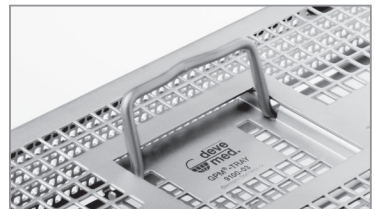

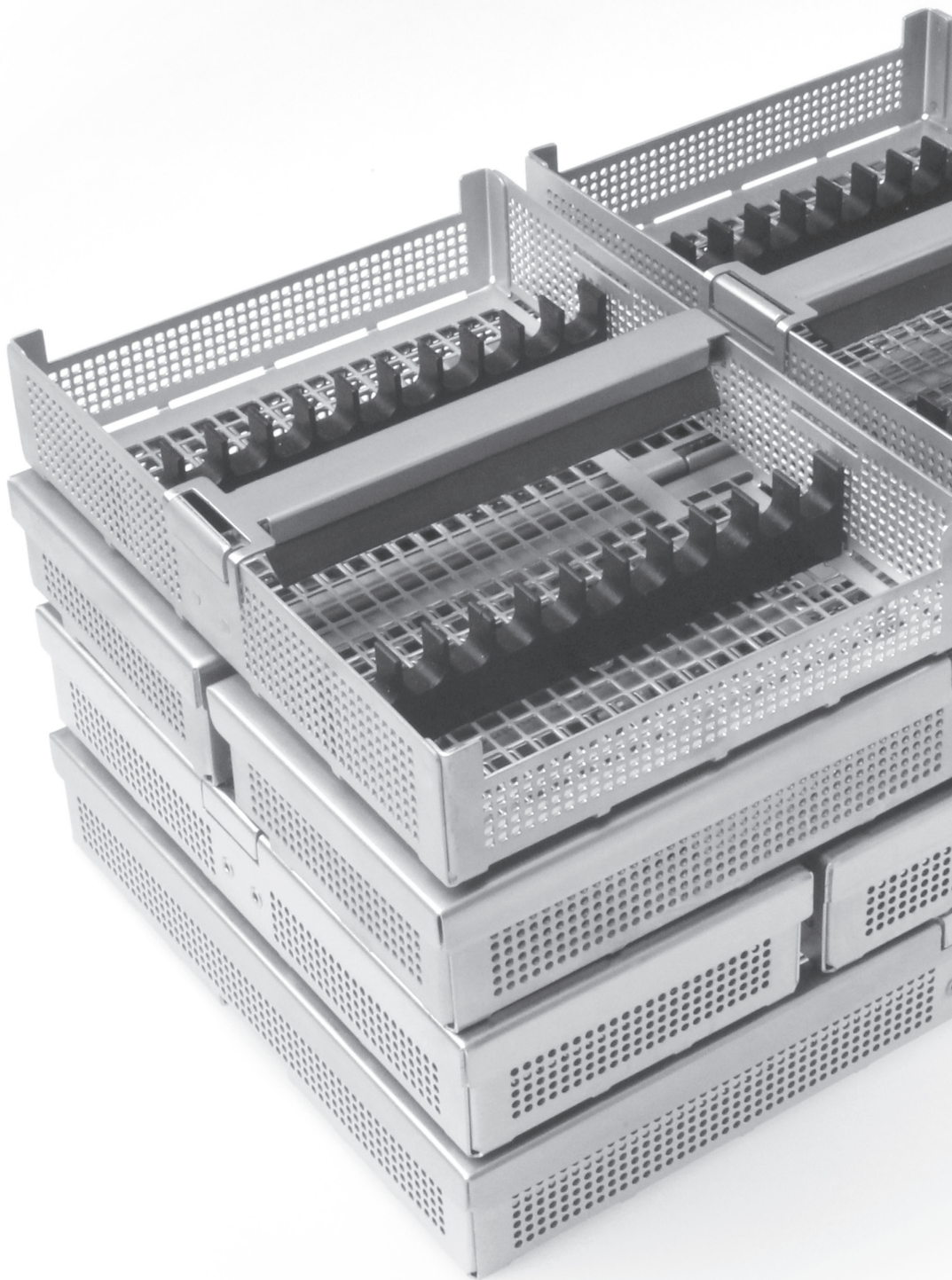

Basis-Auswahl  
Basic Selection  
Sélection de Base

## TRAYS MIT CLIP

TRAYS WITH CLIP  
CASSETTES AVEC CLIP

**9100-05**



271,5 x 177,5 x 33,0 mm

Leer | Mit Clip  
Empty | With Clip  
Vide | Avec Clip

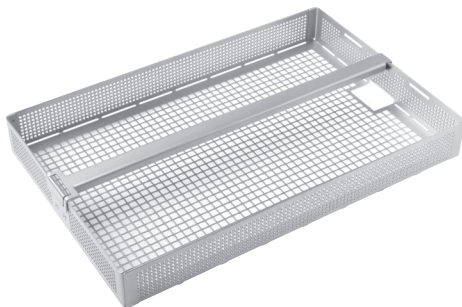

**9100-07**



177,5 x 127,5 x 33,0 mm

Leer | Mit Clip  
Empty | With Clip  
Vide | Avec Clip

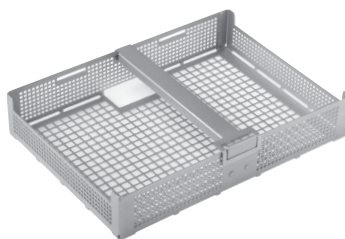

**9100-09**



177,5 x 84,5 x 33,0 mm

Leer | Mit Clip  
Empty | With Clip  
Vide | Avec Clip

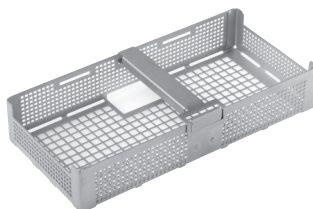

## TRAYS MIT DECKEL

TRAYS WITH TOP COVER  
CASSETES AVEC COUVERCLE

### 9100-00



275,0 x 180,0 x 35,0 mm

Leer | Mit Deckel & Griff  
Empty | With cover & handle  
Vide | Avec couvercle & poignée



### 9100-03



275,0 x 78,0 x 35,0 mm

Leer | Mit Deckel & Griff  
Empty | With cover & handle  
Vide | Avec couvercle & poignée

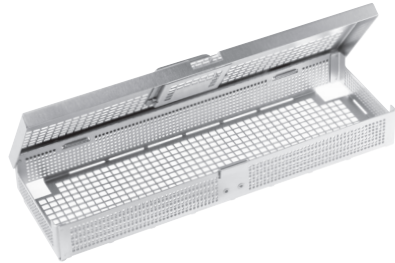

### 9100-01



275,0 x 78,0 x 35,0 mm

Leer | Mit Deckel | Ohne Griff  
Empty | With cover | Without handle  
Vide | Avec couvercle | Sans poignée

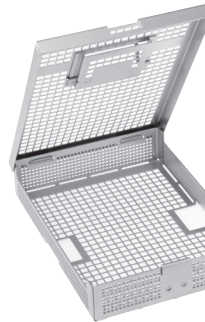
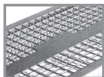

### 9100-04



180,0 x 130,0 x 35,0 mm

Leer | Mit Deckel & Griff  
Empty | With cover & handle  
Vide | Avec couvercle & poignée



### 9100-02



180,0 x 87,0 x 35,0 mm

Leer | Mit Deckel | Ohne Griff  
Empty | With cover | Without handle  
Vide | Avec couvercle | Sans poignée

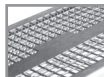

# 3 RACKS OPTIONS

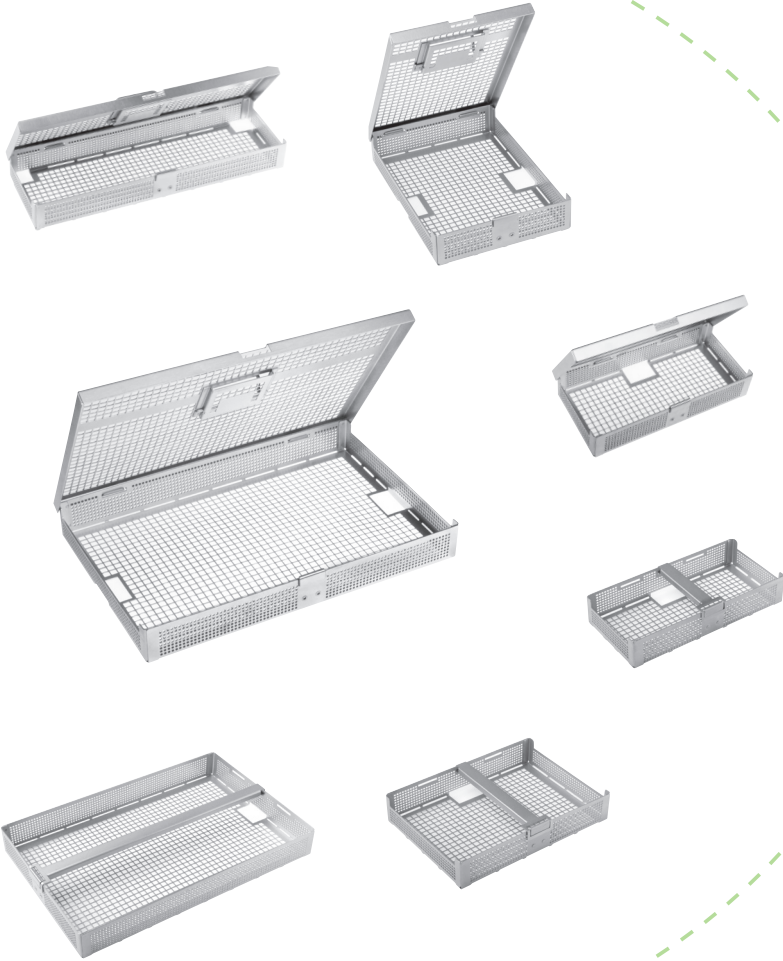

## OPTION 1

### TEFLON®-STEGE

TEFLON®-RACKS  
SUPPORTS EN TÉFLON®



mit Schrauben befestigt  
fastened with screws  
fixés avec des vis

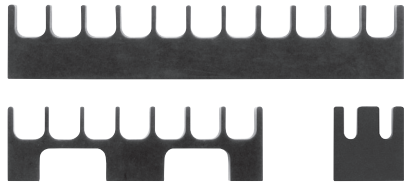

## OPTION 2

### SILIKON-STEGE

SILICONE-RACKS  
SUPPORTS EN SILICONE



mit Montagehilfe befestigt  
fastened with mounting aids  
fixés avec pivots de montage

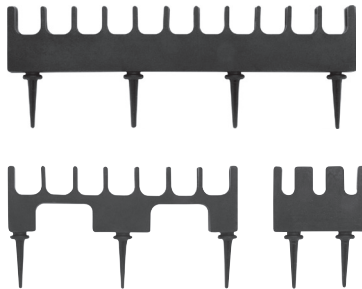

## OPTION 3

### SILIKON-FORMSTEGE

SILICONE FORM RACKS  
SUPPORTS EN SILICONE



mit Montagehilfe befestigt  
fastened with mounting aids  
fixés avec pivots de montage

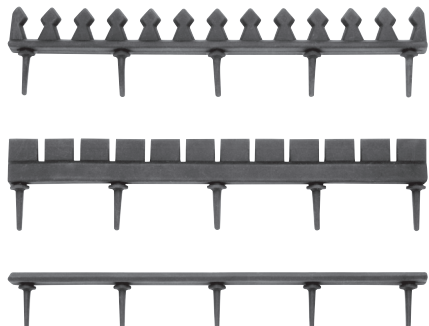

## TRAYS MIT TEFLON®-STEGEN

TRAYS WITH TEFLON®-RACKS

CASSETTES AVEC SUPPORTS EN TÉFLON®

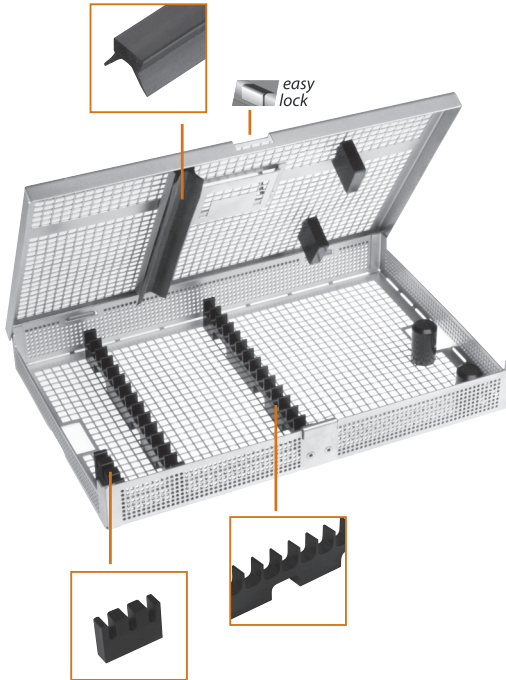

- ✓ Especially suitable for superlight handles
- ✓ Various length (fix)
- ✓ Storage on two levels
- ✓ Fastened with screws



Die Stege und PPSU Halterungen werden mit Schrauben im Tray befestigt.

Teflon-racks and PPSU Holders are fastened to the tray with screws.

Support en téflon et PPSU Crochets sont fixés avec des vis dans le cassette.

Platzsparendes System für Rundgriffe.

Compact system for rounded handles.

Système faiblement encombrant pour poignées rondes.

Instrumente können auf zwei Ebenen platziert werden (Stege mit Brücken).

Instruments can be placed on two levels (racks with bridges).

Les instruments peuvent être placés sur deux niveaux différents (supports avec ponts).

## TEFLON®-STEGE

TEFLON®-RACKS

SUPPORTS EN TÉFLON®

Artikel-Nr. Item no. Articles-Réf.	Instrumente Instruments Instruments	
<b>9900-05</b>	23	251,9 x 23,0 x 8,0 mm
<b>9900-04</b>	11	122,3 x 23,0 x 8,0 mm
<b>9900-01</b>	9	100,7 x 23,0 x 8,0 mm
<b>9900-13</b>	3	35,9 x 23,0 x 8,0 mm
<b>9900-14</b>	2	25,0 x 23,0 x 8,0 mm



## TRAY-STEGE MIT BRÜCKEN

TRAY-RACKS WITH BRIDGES

SUPPORTS EN TRAY AVEC PONTS

Artikel-Nr. Item no. Articles-Réf.	Instrumente Instruments Instruments		Brücken bridges ponts
<b>9900-00</b>	14	154,7 x 23,0 x 8,0 mm	3
<b>9900-02</b>	7	79,1 x 23,0 x 8,0 mm	2
<b>9900-09</b>	6	68,3 x 23,0 x 8,0 mm	1
<b>9900-08</b>	5	57,5 x 23,0 x 8,0 mm	1



## TRAY-STEGE FÜR PINZETTEN

TRAY-RACKS FOR TWEEZERS

SUPPORTS EN TRAY POUR PRÉCELLES

Artikel-Nr. Item no. Articles-Réf.	Pinzetten Tweezers Précelles	
<b>9900-20</b>	3	32,6 x 23,0 x 8,0 mm
<b>9900-21</b>	2	21,8 x 23,0 x 8,0 mm

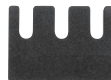

## TRAY-STEGE FÜR AUFSÄTZE

TRAY-RACKS FOR ATTACHMENTS

SUPPORTS EN TRAY POUR EMBOUTS

Artikel-Nr. Item no. Articles-Réf.	Aufsätze Attachements Embouts	
<b>9900-10</b>	6	50,7 x 20,0 x 8,0 mm
<b>9900-11</b>	3	27,3 x 20,0 x 8,0 mm



für Osteotom- & Bone Pusher Aufsatz  
for osteotome- & bone pusher attachment  
pour embouts d'ostéotomes et fousloirs à os

Detaillierte Zusammenstellung  
Detailed Compilation  
Compilation Détaillée

## TRAY BAUSTEINE

TRAYS MODULES

ÉLÉMENTS SUPPLÉMENTAIRES

<b>9900-30</b>	28,0 mm
<b>9900-31</b>	11,2 mm
<b>Halterung</b> Holder Crochet	Ø 16,5 mm

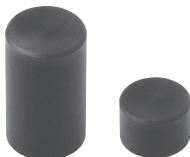

PPSU | für Ringgriffinstrumente  
PPSU | for ring handle instruments  
PPSU | pour instruments à anneaux

<b>9900-40</b>	
<b>Fixierer</b>	25,0 mm
<b>Pusher</b>	23,0 mm
<b>Gächette</b>	8,0 mm



<b>9900-50</b>	
<b>Halterung</b>	20,0 mm
<b>Holder</b>	22,0 mm
<b>Crochet</b>	8,0 mm

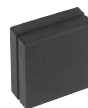

für Trennblech Art. No. 9900-70  
for separating plate no. 9900-70  
pour séparation tôle no. 9900-70

<b>9900-70</b>	
<b>Trennblech</b>	163,0 mm
<b>Separating plate</b>	28,0 mm
<b>Séparation tôle</b>	



<b>9900-80</b>	155 mm
<b>9900-81</b>	250 mm
<b>9900-82</b>	68 mm
<b>9900-83</b>	115 mm
<b>Silikonleiste für Traydeckel</b> Silicone band for tray cover Joint en silicone pour couvercle	



<b>9900-90</b>	155 mm
<b>9900-92</b>	68 mm
<b>9900-93</b>	115 mm
<b>Metallführung für Silikonleiste</b> Metal guides for silicone band Barre métallique pour joint en silicone	



## TRAYS MIT TEFLON®-STEGEN

TRAYS WITH TEFLON®-RACKS

CASSETTES AVEC SUPPORTS EN TÉFLON®

### 9200-90

271,5 x 177,5 x 33,0 mm

für 23 Instrumente  
for 23 instruments  
pour 23 instruments

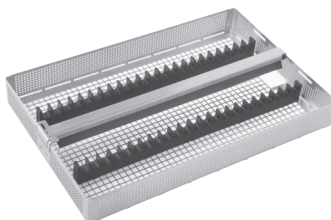

### 9200-80

177,5 x 127,5 x 33,0 mm

für 11 Instrumente  
for 11 instruments  
pour 11 instruments

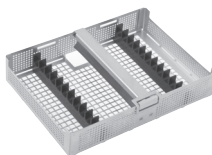

### 9200-70

177,5 x 84,5 x 33,0 mm

für 7 Instrumente  
for 7 instruments  
pour 7 instruments

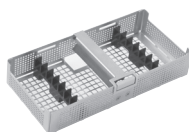

### 9200-10

275,0 x 180,0 x 35,0 mm

mit Deckel und Haltegriff, 2 Stegen für 14 Instrumente, 1 Lagersteg für Pinzetten und 2 Haltebolzen  
with top cover and handhold, 2 racks for 14 instruments, 1 rack for tweezers and 2 holding bolts  
avec couvercle et poignée, 2 supports pour 14 instruments, 1 support pour précelles et 2 plots

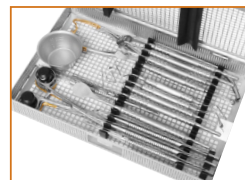
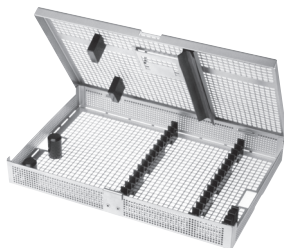

Detaillierte Zusammenstellung  
Detailed Compilation  
Compilation Détaillée

## TRAYS MIT SILIKON-STEGEN

TRAYS WITH SILICONE-RACKS

CASSETTES AVEC SUPPORTS EN SILICONE



Diese neuen Silikonstege sind eine Alternative zu unseren bewährten Teflonstegen. Das Silikon verhindert das Herumrutschen der Instrumente im Steg sowie des Trays auf dem Tisch. Durch die Montagehilfen (Stifte) werden keine Schrauben mehr benötigt und Beschädigungen der Unterlage werden ausgeschlossen.



These new silicone bars are an alternative to our Teflon bars. The silicone prevents the instruments from sliding at the bar as well as of the tray on the table. The mounting aids (pins) eliminate the need for screws and prevent damage to the base.



Ces nouveaux supports en silicone constituent une alternative à nos supports de Teflon. Le silicone prévient tout glissement des instruments sur le support ainsi que de la cassette sur la table. Grâce aux pivots de montage, plus aucune vis n'est nécessaire et il est ainsi possible d'exclure toute détérioration de la base.

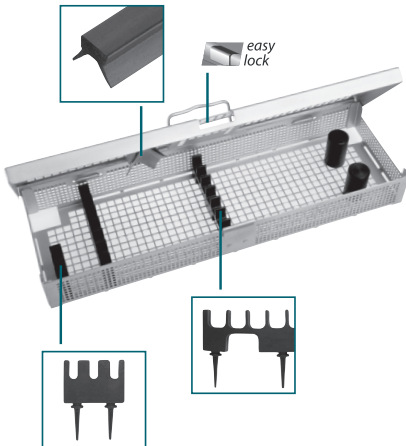

- ✓ Especially suitable for superlight handles
- ✓ No screws necessary
- ✓ Storage on two levels
- ✓ No slithering on the table or inside the rack
- ✓ Easily and fast adaptable for user



Montagehilfen mit kreisenden Bewegungen durch das Tray-Gitter ziehen.

Use circular movements to pull assembly aids through the mesh of the tray.

Tirer les pivots de montage à travers le maillage de la cassette en effectuant des mouvements rotatifs.



Die Montagehilfen mit der Schere abschneiden.

Cut off the assembly aids using scissors.

Couper les pivots de montage à l'aide d'une paire de ciseaux.

## SILIKON-STEGE

SILICONE-RACKS

SUPPORTS EN SILICONE

Artikel-Nr. Item no. Articles-Réf.	Instrumente Instruments Instruments	
<b>9900-04 S</b>	11	123,0 x 23,0 x 8,0 mm



## TRAY-STEGE MIT BRÜCKEN

TRAY-RACKS WITH BRIDGES

SUPPORTS EN TRAY AVEC PONTS

Artikel-Nr. Item no. Articles-Réf.	Instrumente Instruments Instruments		Brücken bridges ponts
<b>9900-00 S</b>	14	154,7 x 23,0 x 8,0 mm	3
<b>9900-02 S</b>	7	79,1 x 23,0 x 8,0 mm	2

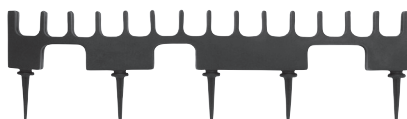

## TRAY-STEGER FÜR PINZETTEN

TRAY-RACK FOR TWEEZERS

SUPPORT EN TRAY POUR PRÉCELLES

Artikel-Nr. Item no. Articles-Réf.	Pinzetten Tweezers Précelles	
<b>9900-20 S</b>	3	32,6 x 23,0 x 8,0 mm



## HALTERUNG FÜR RINGGRIFFINSTRUMENTE

HOLDER FOR RING HANDLE INSTRUMENTS

CROCHET POUR INSTRUMENTS À ANNEAUX

<b>9900-30 S</b>	
	28 mm Ø 16,5 mm



Detaillierte Zusammenstellung  
Detailed Compilation  
Compilation Détaillée

## TRAYS MIT SILIKON-STEGEN

TRAYS WITH SILICONE-RACKS

CASSETTES AVEC SUPPORTS EN SILICONE

### 9200-80 S

177,5 x 127,5 x 33,0 mm

für 11 Instrumente  
for 11 instruments  
pour 11 instruments

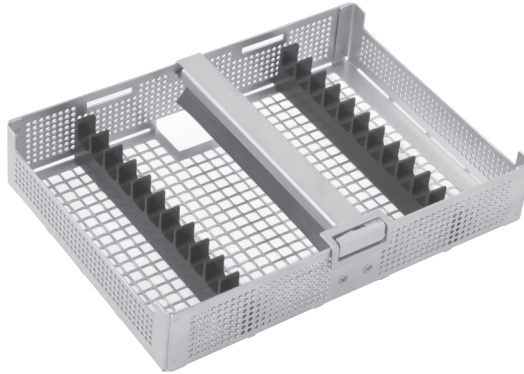

### 9200-70 S

177,5 x 84,5 x 33,0 mm

für 7 Instrumente  
for 7 instruments  
pour 7 instruments

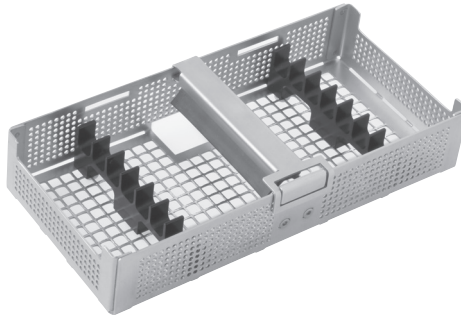

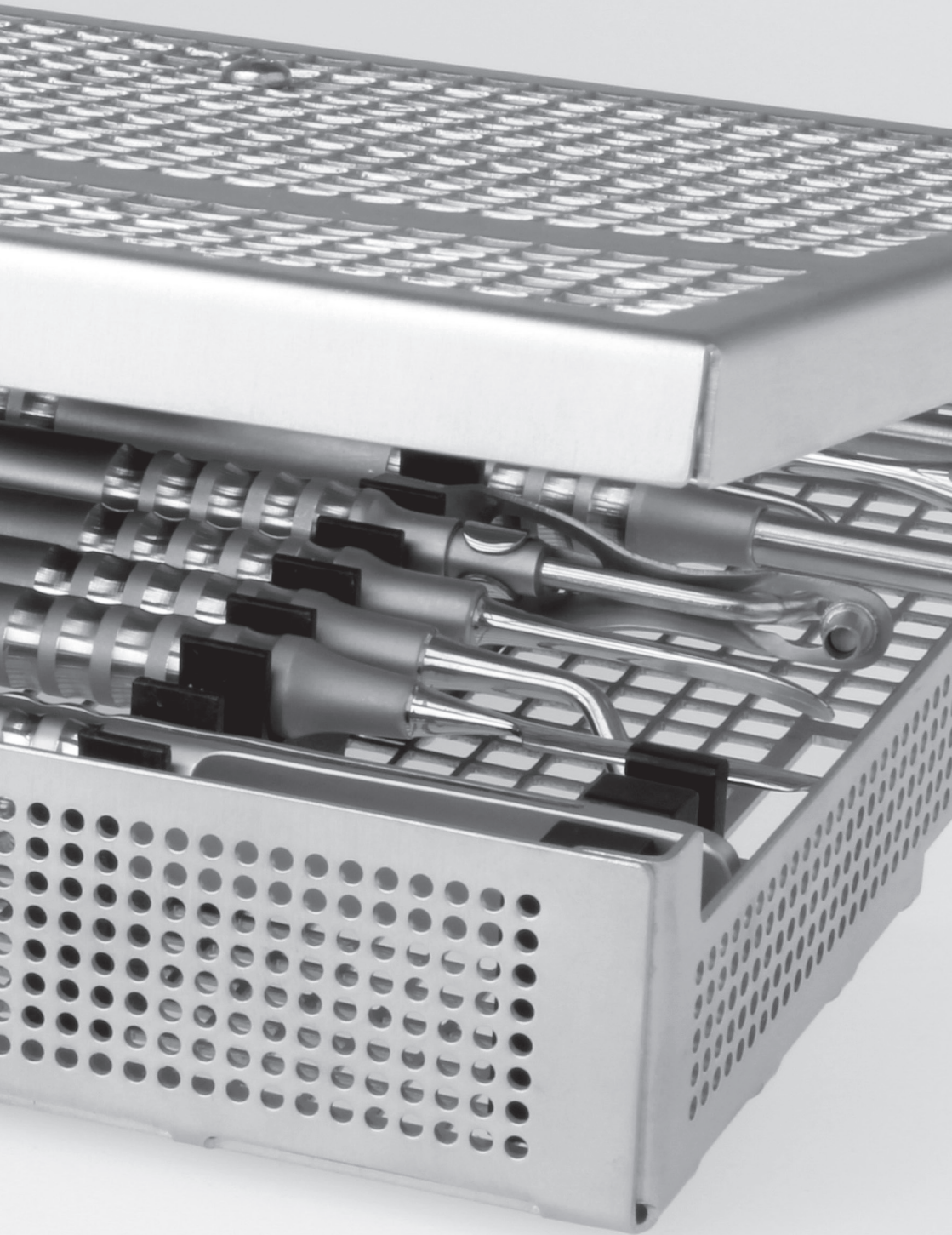

Detaillierte Zusammenstellung  
Detailed Compilation  
Compilation Détaillée

## TRAYS MIT SILIKON-STEGEN

TRAYS WITH SILICONE-RACKS

CASSETTES AVEC SUPPORTS EN SILICONE

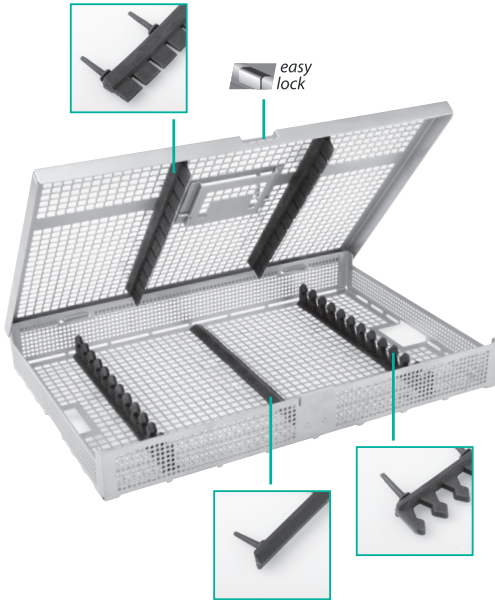

- ✓ No slithering on the table or inside the rack
- ✓ Suitable for all instruments
- ✓ No screws necessary
- ✓ Individual cutting with scissors
- ✓ Easily and fast adaptable for user

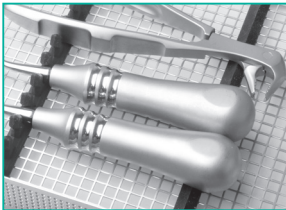

Besonders geeignet für Instrumente wie Zangen, Hebel...

Particularly suited to instruments such as forceps, levers, ...

Convient particulièrement aux instruments comme les pinces, leviers, ...

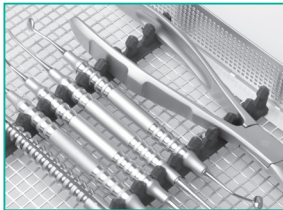

Flexibel einsetzbar durch das Nachgeben der Zapfen.

Flexible positioning due to the adaptable pegs.

Utilisation flexible grâce au relâchement des ergots.

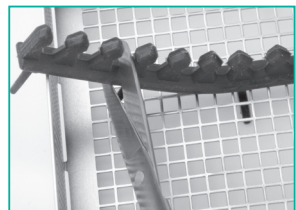

Schnelles und einfaches Anpassen der Silikonsteglänge mit der Schere.

Fast and easy adjustment of the length of the silicone racks using scissors.

Ajustement rapide et simple de la longueur des supports en silicone à l'aide d'une paire de ciseaux.

## SILIKON-FORMSTEGE

### SILICONE-FORM RACKS

### SUPPORTS EN SILICONE EN FORME

#### 9901-10

# 12

160,0 mm  
18,0 mm  
10,0 mm

geformt  
shaped  
profilé



#### 9901-50

Niederhalter  
Downholder  
Dispositif de retenue

160,0 mm  
17,0 mm  
7,0 mm

hoch  
tall  
haut

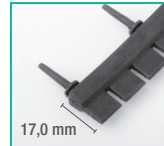

#### 9901-20

Universal

160,0 mm  
17,0 mm  
5,0 mm

flach  
plane  
plate



Montagehilfen mit kreisenden Bewegungen durch das Tray-Gitter ziehen.

Use circular movements to pull assembly aids through the mesh of the tray.

Tirer les pivots de montage à travers le maillage de la cassette en effectuant des mouvements rotatifs.

Die Montagehilfen mit der Schere abschneiden.

Cut off the assembly aids using scissors.

Couper les pivots de montage à l'aide d'une paire de ciseaux.



**devemed GmbH**

take-off GewerbePark 30  
78579 Neuhausen ob Eck  
Germany

Tel: +49 (0) 74 67 - 949 199 0  
info@devemed.de

www.devemed.de  
www.devemed-dental-shop.de

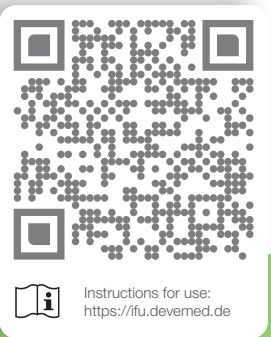

CE | CE 0483

Rev\_05/26

Alle aufgeführten Medizinprodukte sind mit dem CE-Zeichen versehen. Bei Produkten höherer Klasse I wird über die Kennzeichnung zusätzlich die Kennnummer 0483 unserer Benannten Stelle ausgewiesen. Bei Medizinprodukten, die wir lediglich handeln, finden Sie auf den entsprechenden Seiten jeweils einen Hinweis.

All listed medical devices bear the CE mark. Products above Class I also bear the identification number 0483 of our notified body. Medical devices that we merely distribute are marked accordingly on the relevant pages.

Tous les dispositifs médicaux mentionnés sont munis du marquage CE. Pour les produits de classe supérieure à I, le numéro d'identification 0483 de notre organisme notifié est également indiqué sur le marquage. Pour les dispositifs médicaux que nous commercialisons uniquement, vous trouverez une mention correspondante sur les pages correspondantes.